

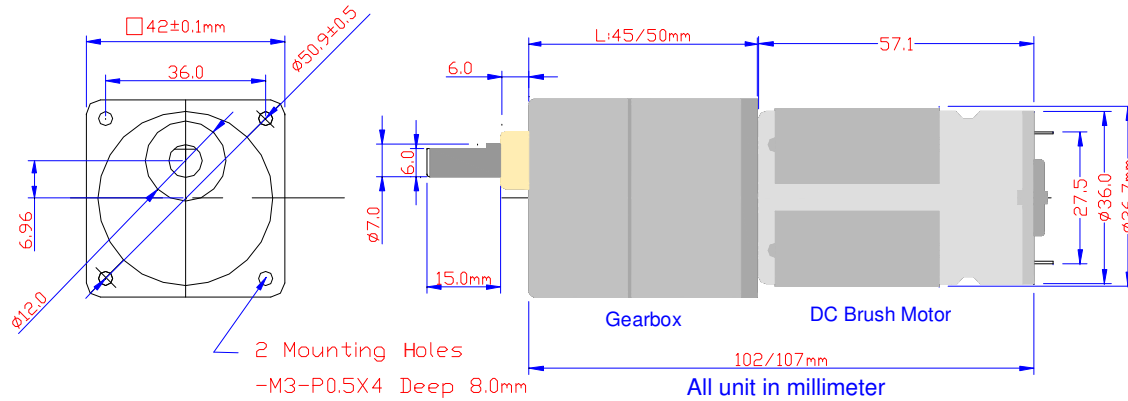

## HG42KD Series of DC Brush Gear Motor



(A).Standard DC Motor Specifications :

RATED VOLTAGE	NO LOAD		AT MAXIMUM EFFICIENCY				STALL		
NORMAL	SPEED	CURRENT	SPEED	CURRENT	TORQUE	OUTPUT	EFF	CURRENT	TORQUE
	rpm	A	rpm	A	g-cm	W	%	A	g-cm
12.0V CONSTANT	3600	0.2	3010	0.080	180	5.6	67	3.4	1100
12.0V CONSTANT	5000	0.13	4350	0.6	216	9.7	71	3.9	1706
12.0V CONSTANT	10000	0.7	8630	4	395	35.0	48	27.7	3040
12.0V CONSTANT	15000	1.4	13500	6.9	420	59.0	71	46.0	3200
24.0V CONSTANT	5000	0.3	4300	0.63	230	10.2	19	3.6	1668
24.0V CONSTANT	10000	0.3	8190	1.6	320	26.9	47	10.4	2500

(B).Gearbox Specifications :

Reduction Ratio	Rated Tolerance Torque	Max. Momentary Tolerance Torque	Efficiency	Radial Play of Shaft	Thrust Play of Shaft	(L)
						Length
1/20	6 kgf-cm Max	25 kgf-cm	66%	≅ 0.1 mm	≅ 0.35 mm	40.0
1/62	10 kgf-cm Max	35 kgf-cm	59%			40.0
1/104, 1/188	15 kgf-cm Max	50 kgf-cm	53%			45.0
1/312, 1/562	20 kgf-cm Max	60 kgf-cm	53%			45.0
1/936	25 kgf-cm Max	70 kgf-cm	48%			45.0
1/1684	30 kgf-cm Max	80 kgf-cm	43%			45.0